



BAUER

FOR A GREEN WORLD

Submersible Motor Pump MAGNUM CSP/ESP

The NEW BAUER pump impresses with singular performance, versatile application and long lifespan.

Flow rate of 80m³/h at a discharge head of 13 m and drive speed of 1450 U/min

Outstanding cutting performance

New design of cutting device made of high quality chrome-steel

Submersible rotary motor 4.0–5.5–7.5 kW with insulation class H (optional)

Higher flow rate efficiency class IE 2

Temperature control for application in biogas plants

Additional security thanks to leakage sensors (optional)

30% higher efficiency achieved than at competitor models

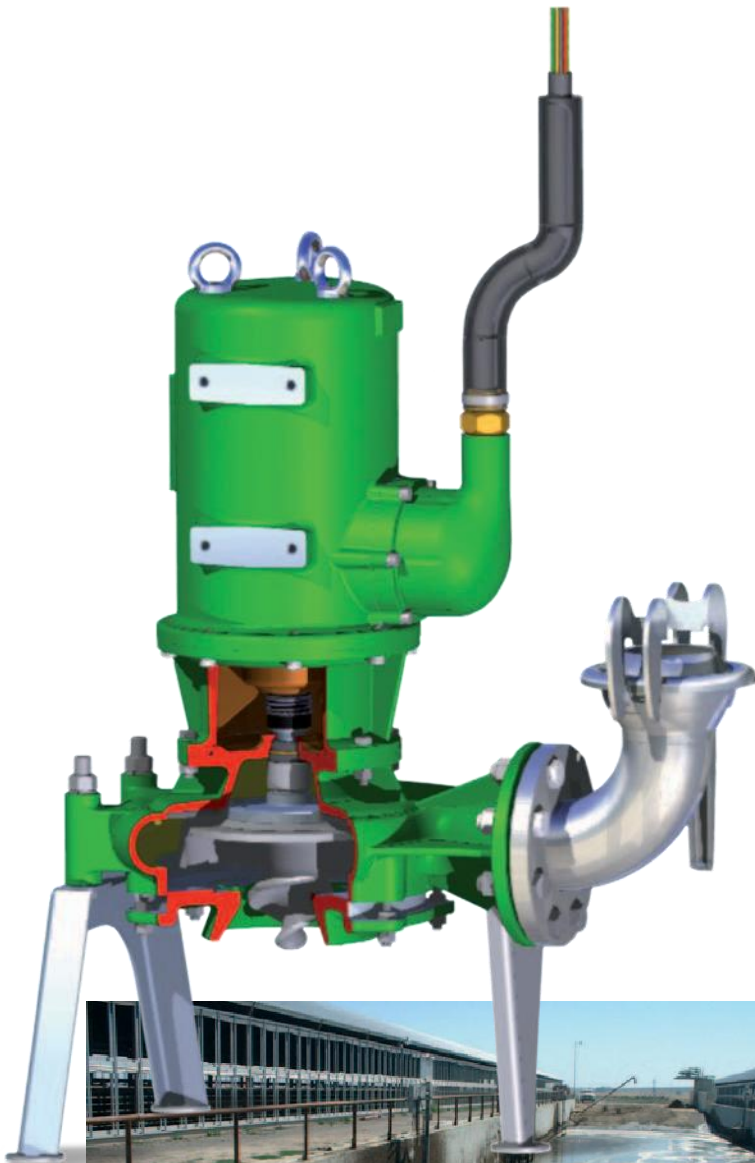



BAUER

FOR A GREEN WORLD

Submersible Motor Pump MAGNUM CSP/ESP

The unique design of the MAGNUM CSP

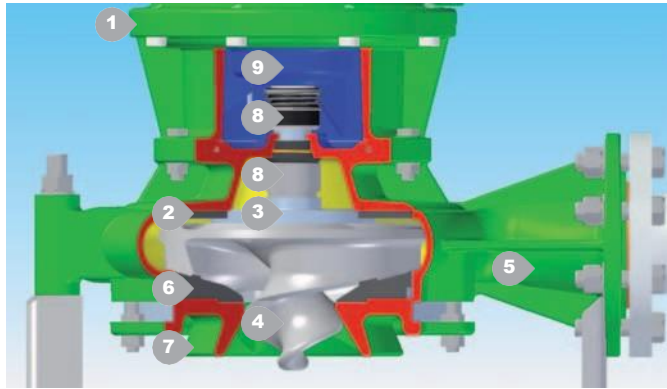

- | | |
|---------------------|----------------------|
| 1 Submersible motor | 6 Cutting device |
| 2 Wear disc | 7 Suction bell |
| 3 Flange disc | 8 Mechanical sealing |
| 4 Impeller | 9 Oil collection |
| 5 Spiral housing | |

Longlifespan

The new cutting device of the MAGNUM CSP is adjustable and easy to replace. The use of high quality chrome-steel clearly improves the lifespan of the pump.

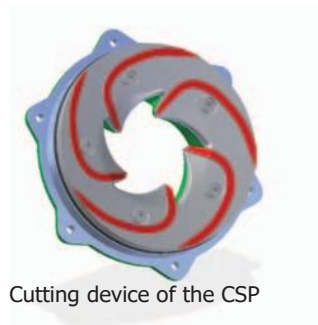

Cutting device of the CSP



Suction bell of the ESP

Higher flow rate

The new designed suction bell of the MAGNUM CSP accelerates the flow of the media.

Characteristic curves MAGNUM CSP/ESP

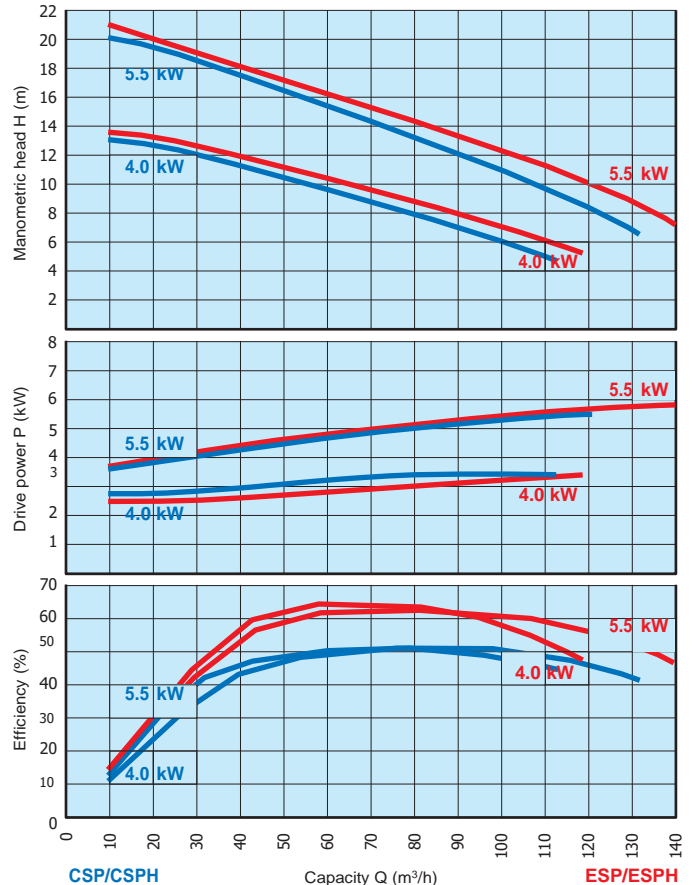

Submersible Motor Pump MAGNUM CSP with cutting device

Model	Discharge m³/h	Discharge head m	max. drive power kW	max. Ampere	drive speed min ⁻¹	Delivery connection mm
CSP 4	20 – 100	12.3 – 5.9	4.0	8.1	1450	DN 80
CSP 5.5	20 – 120	19.2 – 8.2	5.5	10.7	1450	DN 80
CSP 7.5	20 – 120	19.2 – 8.2	7.5	14.9	1445	DN 80

The CSP 7.5 / 50 Hz has the same hydraulic values as the CSP 5.5 (but with larger cutting reserves)

Submersible Motor Pump MAGNUM ESP without cutting device

Model	Discharge m³/h	Discharge head m	max. drive power kW	max. Ampere	drive speed min ⁻¹	Delivery connection mm
ESP 4	20 – 100	13.0 – 7.0	4.0	8.1	1450	DN 80
ESP 5.5	20 – 120	20.0 – 9.8	5.5	10.7	1450	DN 80

Your dealer:

MCTECH CÔNG TY TNHH CÔNG NGHỆ MINH CHÂU
 MINH CHAU TECHNOLOGY CO. LTD
 Địa chỉ: 787 Trường Định, Phường Thịnh Liệt, Quận Hoàng Mai, Hà Nội
 Điện thoại: 84 24 36422671/ 39950965 Fax: 84 24 36422864
 Email: info@mctech.com.vn http://www.mctech.com.vn

Röhren- und Pumpenwerk BAUER Ges.m.b.H.
 8570 Voitsberg, Austria
 Phone +43 3142 200-0
 Fax +43 3142 200-320 / -340
 sales@bauer-at.com
 www.bauer-at.com



A BAUER Group company