



- > **SEPARATOR S300**
- > SEPARATOR S655
- > SEPARATOR S855
- > SEPARATOR S855 GB
- > PLUG & PLAY



EN



WASTE WATER TREATMENT

# SEPARATOR S300

ECONOMIC SLURRY TREATMENT



[WWW.BAUER-AT.COM](http://WWW.BAUER-AT.COM)



# SEPARATOR S300

**Minimal total costs: energy  
efficient plus low initial  
investment**

- Optimum cost-performance ratio
- Low operating costs
- Less space required
- Ideal for small farms with limited energy resources
- Wide range of Agricultural based applications
- Long life of wearing components

## **We help to grow.**

With our extensive range of slurry products we offer you the right tools. Since 1930 we have not only been concerned about the perfect equipment for the transportation of manure but also have been caring about the right treatment and spreading of manure. Furthermore, we are specialized in developing innovative solutions for the optimal and efficient preparation of manure.

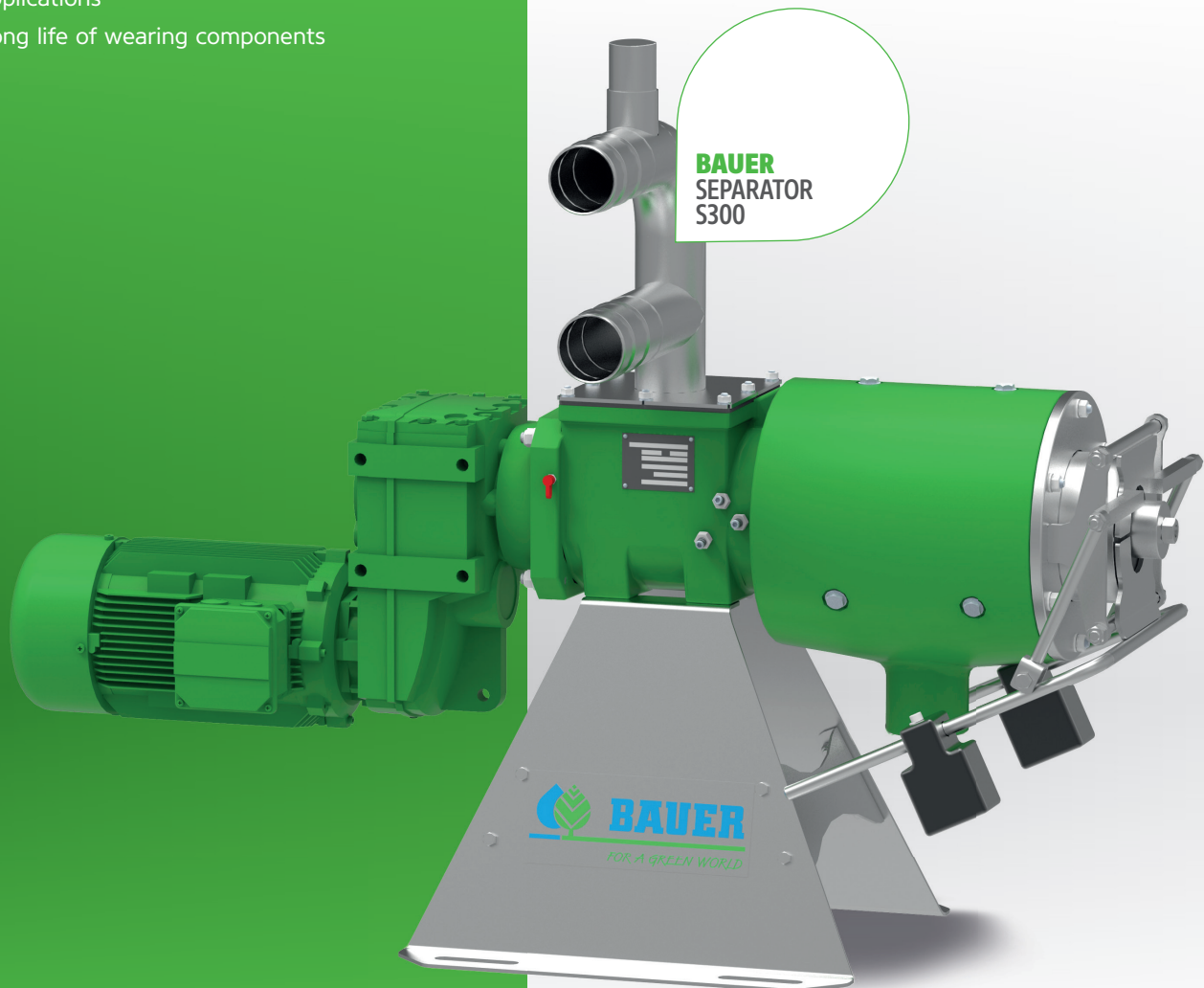

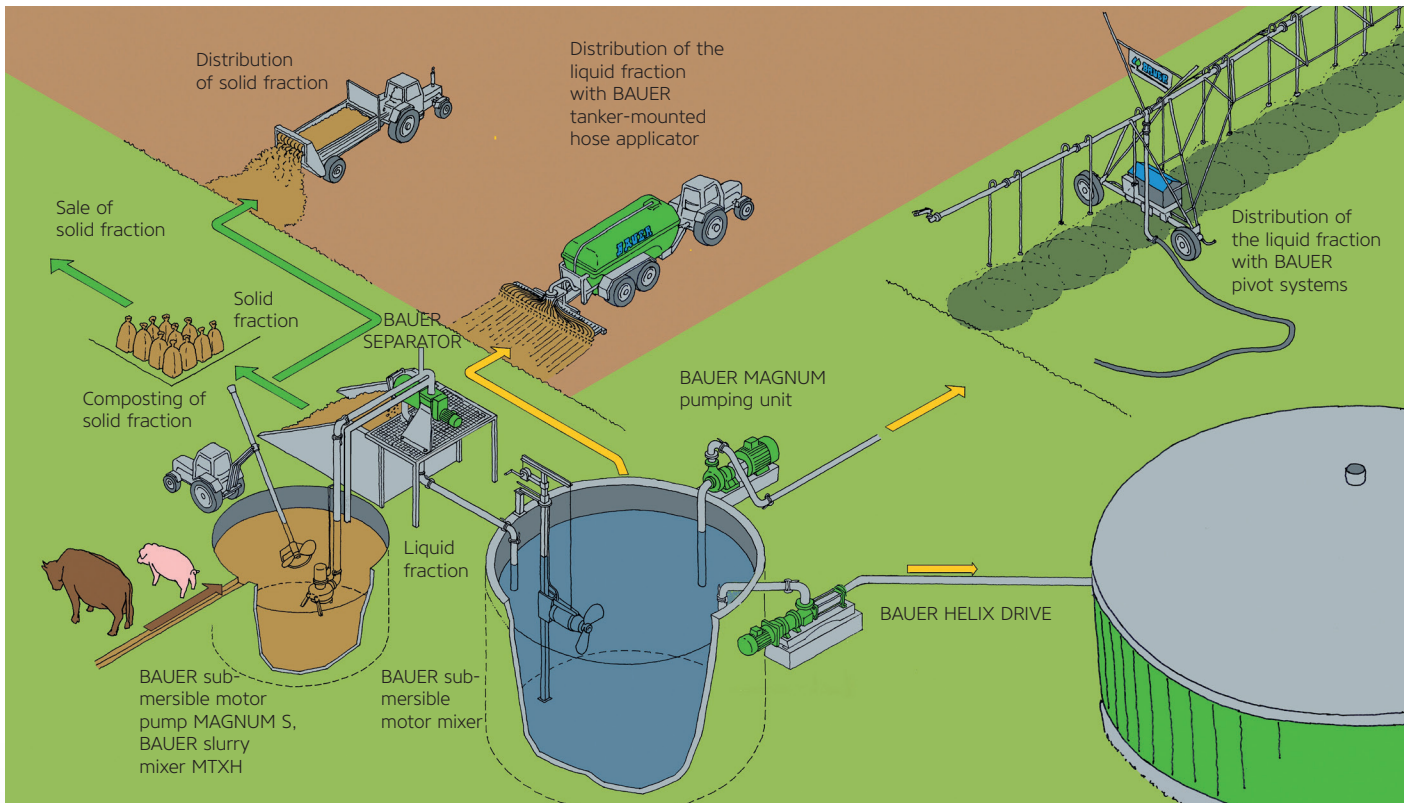

BAUER technology leads in the separation of liquid from solid nutrients.

### Product Description

The new design Press Screw Separator 300 is a machine to separate solids and liquids with a rotating auger inside a full floating screen.

The medium is drained in the first part of the screen by gravitation. In the second step the medium is additionally extruded and exits the separator at the mouth piece.

In order to control dry matter content an output regulator is installed on the separator.

### Site Suitability

The successor of the globally successful Compact Separator is a lower-cost alternative to the existing BAUER S655 line.

Where no separator is currently installed and the separation process will cut cost or add value.

### Features and Benefits

- 2.2 kW motor
- Throughput up to 16 m<sup>3</sup>/h
- Dry matter content up to 32%

### Technical Data

Throughput, m <sup>3</sup> /h	up to 16
Dry matter content, %	32
Input power, kW	2.2
Screen sizes, mm	0.25 - 0.5 - 0.75 - 1.0

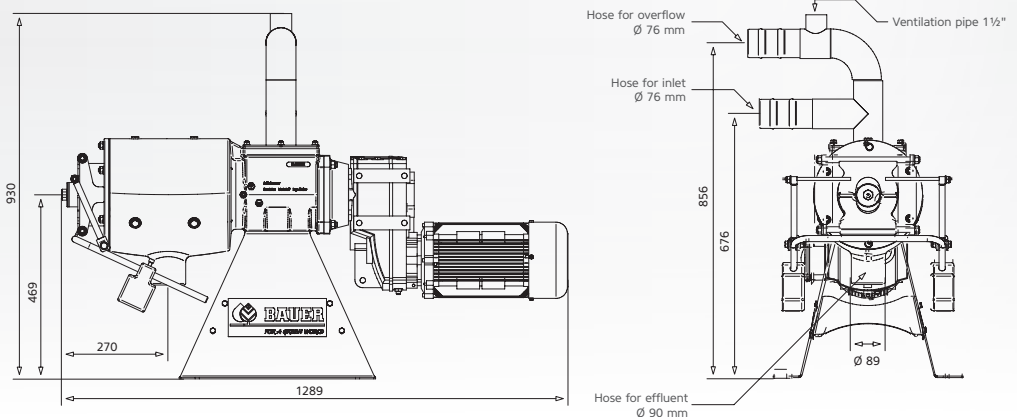



PRODUCTS FROM OUR SLURRY PROGRAM



**MTXH**  
Tractor mixer



**MSXH**  
Submersible motor mixer



**SEPARATOR**  
Press screw separator for  
solid-liquid separation



**SEPARATOR PLUG&PLAY**  
System for portable slurry  
separation

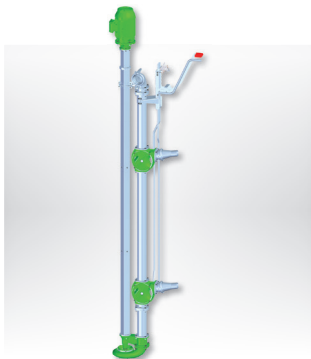

**MAGNUM LEE/LEC**  
Long shaft pump



**MAGNUM SM**  
Thick matter pump gear unit  
design



**MAGNUM CSPH**  
Submersible motor pump gear  
unit design

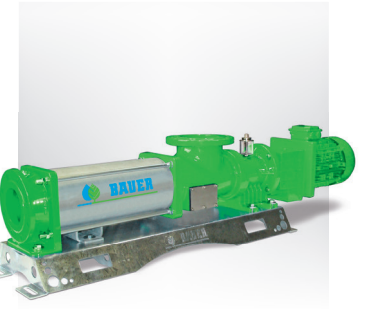

**HELIX DRIVE**  
Eccentric screw pump



**MAGNUM SX**  
Thick matter pump gear and  
pedestal pump



**Slurry tankers and  
polyester tanker**  
Different tanker types for every  
requirement



**Trailing hose applicator**  
Modular system for all types of  
tankers



**Slurry injector**  
Innovative spreading  
technology

Your dealer

Röhren- und Pumpenwerk BAUER GmbH

8570 Voitsberg / Austria

**T** +43 3142 200-0

**F** +43 3142 200-320/-340

**M** sales@bauer-at.com

**W** www.bauer-at.com

